



ARZATOARE PE MOTORINA CU O SINGURA TREAPTA

MODEL:  
G0...-G1...-G2...  
GX3...-GX4...



## CARTE TEHNICA

Instructiuni de montaj, exploatare  
si intretinere

ARZATOARE G0,G1,G2, GX3, GX4





## ARZATOARE PE MOTORINA CU O SINGURA TREAPTA

**MODEL:**  
G0...-G1...-G2...  
GX3...-GX4...

### DATE TEHNICE

TIPUL		G0HR	G0H G0S	G1HR	G1H G1S G1F	G2HR MAXI	G2H MAXI G2S MAXI G2F MAXI
Consum combustibil	kg/h	1.2-3.1	2.0-3.3	2.0-5.0	2.0-5.0	4-9,8	4-9.8
Putere termica	Mcal/h	12,2-31,6	20,4-33,7	20,4-51	20,4-51	40,8-99,9	40,8-99,9
Putere termica	kW	14,2-36,7	23,7-39,1	23,7-59,2	23,7-59,2	47,3-116	47,3-116
Putere electrica motor	W	90	90	100	100	100	100
Preincalzitor	W	30-110	-	30-110	-	30-110	-
Putere electrica absorbita maxima	W	435	325	455	335	335	335
Tip combustibil	MOTORINA 1,5 °E la 20°C = 6,2 cSt=35 sec Redwood Nr.1						
Presiune pompa	10-12 bar (CALIBRARE STANDARD) Max: 15 bar						
Alimentare electrica	Monofazata 230 V (-15% + 10%) 50 Hz						
Gradul de protectie electrica	IP40						
Timp de siguranta al automatului de comanda	=< 10 sec.						

INTERVAL DE LUCRU: Putere termica – Presiune in camera de ardere

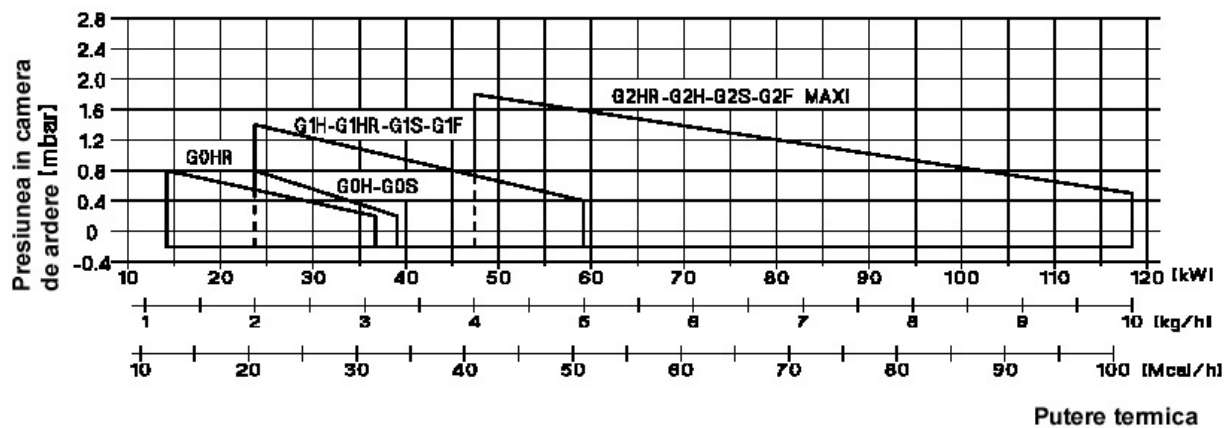

DIMENSIUNI DE GABARIT [mm]

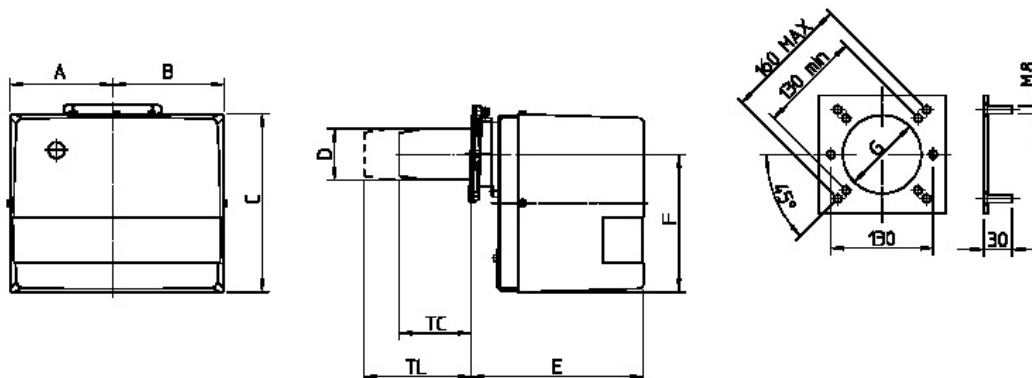

Model	A	B	C	D	E	F	G	TC	TL
G0...2001	137	137	240	80	215	169	90	112	152
G1...2001	157	170	275	80	265	210	90	112	152
G2...MAXI	157	170	275	90	265	210	100	112	152

**CALOR SRL**

Str. Progresul. nr. 30-40, sect. 5, Bucuresti  
Tel/fax: 021/4114444; 4113614 [www.calor.ro](http://www.calor.ro) – [calor@calor.ro](mailto:calor@calor.ro)

pag. 2 din 13



ARZATOARE PE MOTORINA CU O SINGURA TREAPTA

MODEL:  
G0...-G1...-G2...  
GX3...-GX4...

TIPUL		GX3H GX3S GX3F	GX4H GX4S GX4F
Consum combustibil	kg/h	7-15	10-20
Putere termica	Mcal/h	71-153	102-204
Putere termica	kW	83-178	118-236
Putere electrica motor	W	150	200
Preincalzitor	W	-	-
Putere electrica absorbita maxima	W	355	405
Tip combustibil	MOTORINA 1,5 °E la 20°C = 6,2 cSt=35 sec Redwood Nr.1		
Presiune pompa	10-12 bar (CALIBRARE STANDARD) Max: 15 bar		
Alimentare electrica	Monofazata 230 V (-15% + 10%) 50 Hz		
Gradul de protectie electrica	IP40		
Timp de siguranta al automatului de comanda	=< 10 sec.		

INTERVAL DE LUCRU: Putere termica – Presiune in camera de ardere

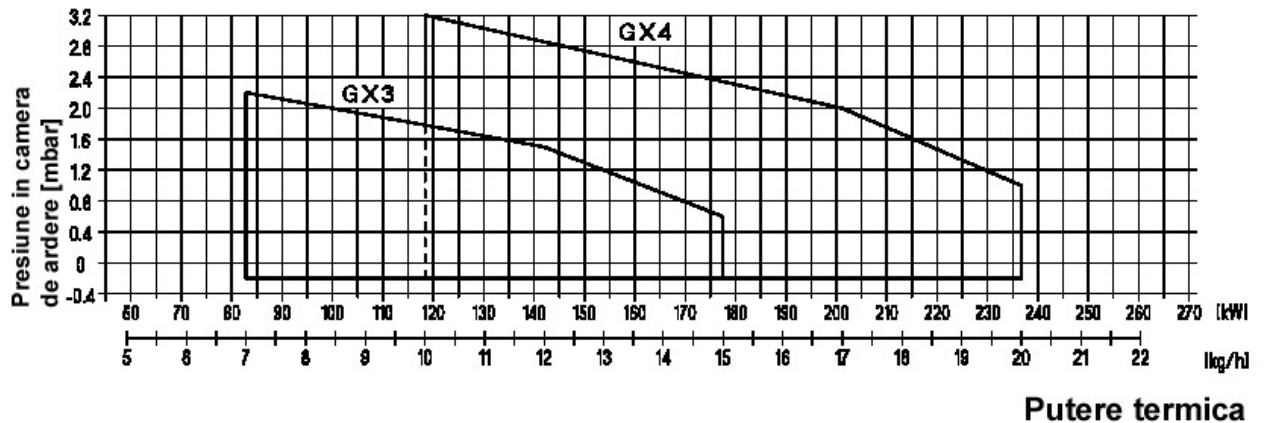

DIMENSIUNI DE GABARIT [mm]

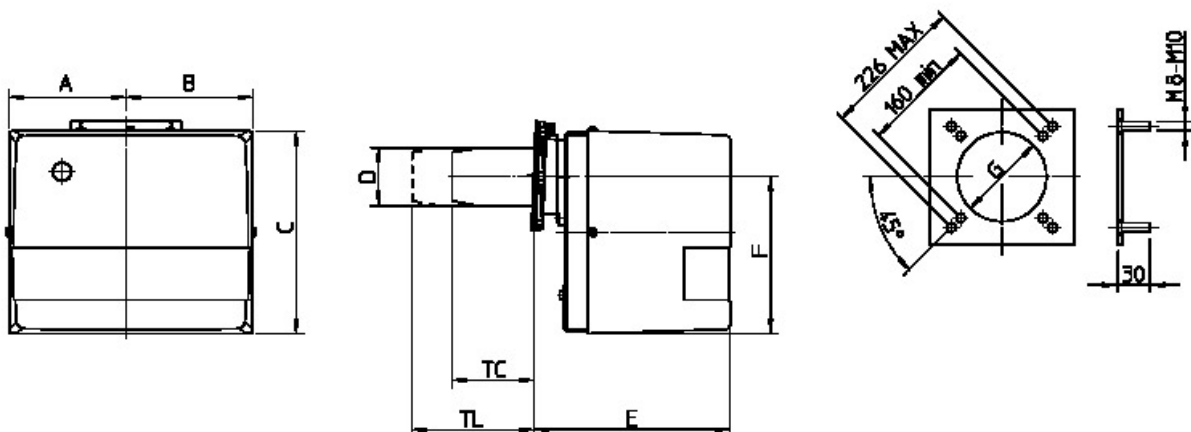

Model	A	B	C	D	E	F	G	TC	TL
GX3...	179	189	318	110	298	248	120	130	250
GX4...	179	189	318	125	298	248	140	130	152

**CALOR SRL**

Str. Progresul. nr. 30-40, sect. 5, Bucuresti  
Tel/fax: 021/4114444; 4113614 [www.calor.ro](http://www.calor.ro) – [calor@calor.ro](mailto:calor@calor.ro)

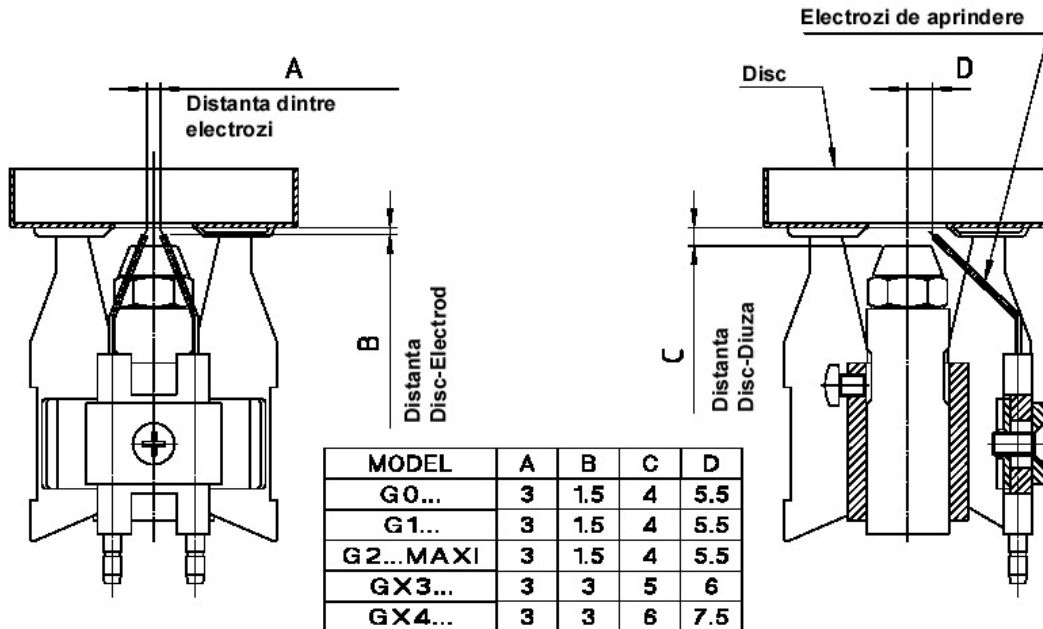
**POZITIONAREA CORECTA A ELECTROZILOR**

**AMORSAREA POMPEI**

Racordati corect tevile de tur si retur (v. sagetile de pe pompa) si asigurati-va ca nu exista puncte de obturare pe retur;  
Realizati aprinderea arzatorului iluminand puternic fotorezistenta si desfaceti surubul de la racordul de masurare a presiunii pana cand iese motorina.

**SCHEMA SISTEMULUI HIDRAULIC SI DIAMETRELE TEVELOR**

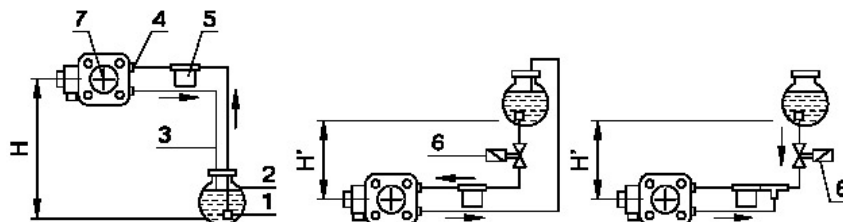
- 1 : Sorb cu filtru
- 2 : Rezervor
- 3 : Retur
- 4 : Aspiratie
- 5 : Filtru in linie
- 6 : Robinet
- 7 : Pompa



INSTALAREA TREBUIE REALIZATA IN CONFORMITATE CU LEGISLATIA LOCALA IN VIGOARE

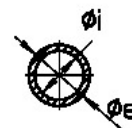
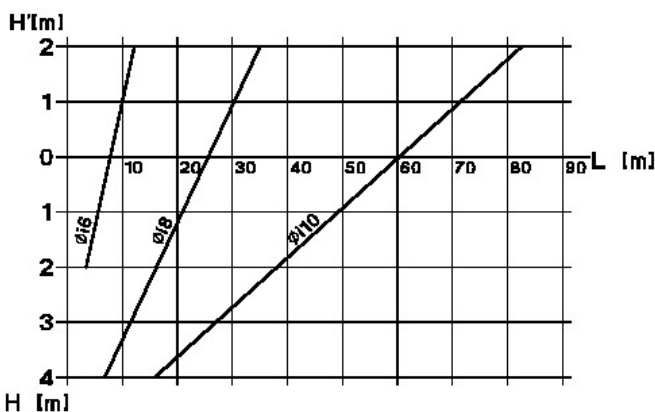

Detaliile se refera la instalatiile care nu prezinta obturari si care au etansari perfecte.

Se recomanda utilizarea tevelor de cupru.

Presiunea negativa nu trebuie sa fie mai mare decat max 0,4 bar.

**TABEL PRIVIND DEBITELE SI POZITIONAREA CLAPETEI DE AER - MODEL G0...**





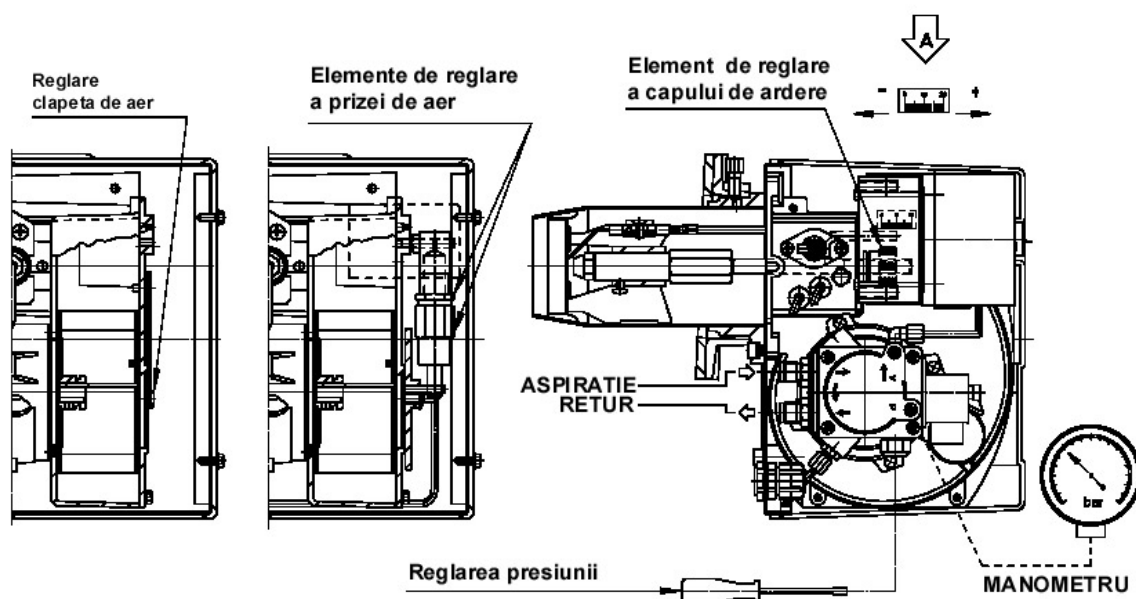

Tablul ofera informatii pentru reglarea maxima a admisiei aerului pentru camera de ardere cu presiunea de 0,01 mbar.  
Reglarea definitiva trebuie facuta in timpul functionarii cu ajutorul unui analizor de gaze.

MODEL	DIUZA G.P.H. x unghi	PRESIUNE [bar]	DEBIT [Kg/h]	PUTERE TERMICA [kW- Mcal/h]	CLAPETA AER [Nr. GRADATII]	CAP ARDERE [Nr. GRADATII]
GOHR	0.40 x 60°S	10	1,2	14.2-12.2	3,5	2
		12	1,4	16.6-14.3	3,5	3
	0.50 x 60°S	10	1,7	20.1-17.3	6,5	5
		12	1,8	21.3-18.4	7	6
	0.60 x 60°S	10	1,9	22.5-19.4	9	8
		12	2,0	23.7-20.4	10	9
	0.65 x 60°S	10	2,2	26-22.4	10	10
		12	2,4	28.4-24.5	11	12
	0.75 x 60°S	10	2,6	30.8-26.5	9	13
		12	2,8	33.1-28.7	9,5	14
	0.85 x 60°S	10	3,1	36.7-31.6	9,5	16
GOH GOS	0.50 x 60°S	10	2,0	23.7-20.4	5	7
		12	2,2	26-22.4	6	7
	0.60 x 60°S	10	2,4	28.4-24.5	7	8
		12	2,6	30.8-26.5	8	9
	0.65 x 60°S	10	2,8	33.1-28.7	9	10
		12	3,0	35.5-30.6	9,5	11
	0.75 x 60°S	12	3,3	39-33.7	10	12

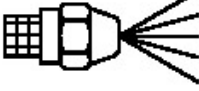

**TABEL PRIVIND DEBITELE SI POZITIONAREA CLAPETEI DE AER - MODEL G1...**





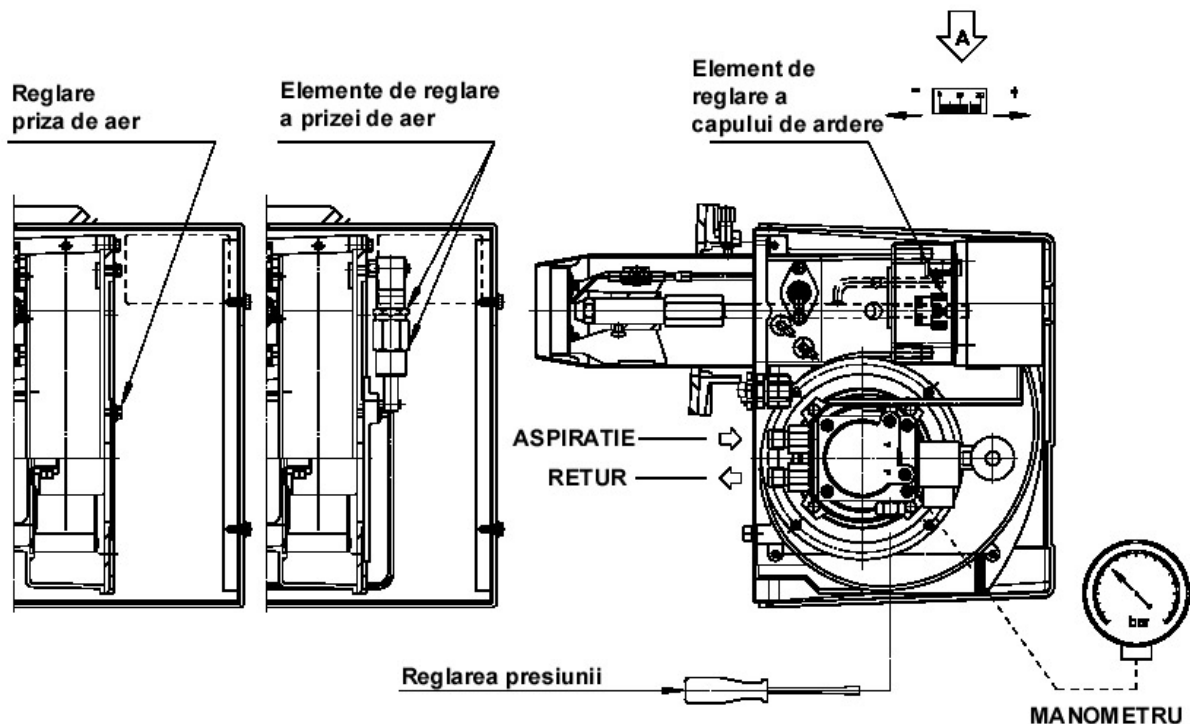

Tabelul ofera informatii pentru reglarea maxima a admisiei aerului pentru camera de ardere cu presiunea de 0,01 mbar. Reglarea definitiva trebuie facuta in timpul functionarii cu ajutorul unui analizor de gaze.

 DIUZA G.P.H. x grd	 PRESIUNE [bar]	 DEBIT [kg/h]	 PUTERE TERMICA [kW-Mcal/h]	 CLAPETA AER [Nr. gradatii]	 CAP ARDERE [Nr. gradatii]
0.50 x 60°S	13	2.0	23.7-20.4	3.5	8
0.65 x 60°S	10	2.7	32 -27.5	5.0	12
	12	2.9	34.3-29.6	5.9	12
0.75 x 60°S	10	3.0	35.5-30.6	5.0	14
	12	3.3	39 -33.7	6.0	14
1.00 x 60°S	10	3.6	42.6-36.7	7.0	16
	12	4.0	47.3-40.8	8.0	16
1.25 x 60°S	10	4.5	53.2-45.9	8.5	20
	12	5.1	60.3-52	9.5	20



**TABEL PRIVIND DEBITELE SI POZITIONAREA CLAPETEI DE AER - MODEL G2...MAXI**





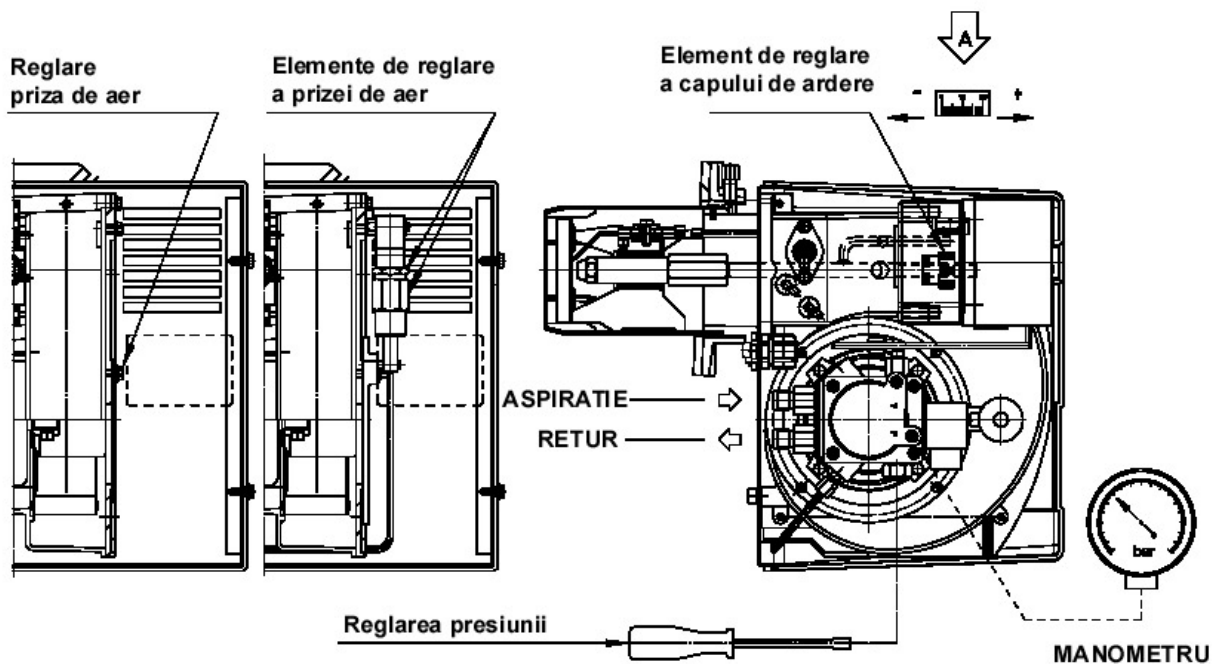

Tabelul ofera informatii pentru reglarea maxima a admisiei aerului pentru camera de ardere cu presiunea de 0,01 mbar. Reglarea definitiva trebuie facuta in timpul functionarii cu ajutorul unui analizor de gaze.

 DIUZA G.P.H. x grade	 PRESIUNE [bar]	 DEBIT [kg/h]	 PUTERE TERMICA [kW-Mcal/h]	 CLAPETA AER [Nr. gradatii]	 CAP ARDERE [Nr. gradatii]
1.25 x 60°S	11	4,8	56,8-49	9	0
	12	5,1	60,3-52	9,5	0
1.50 x 60°S	10	5,6	66,3-57,1	10	3
	12	6	71-61,2	10,5	4
1.75 x 60°S	10	6,5	76,9-66,3	10,5	6
	12	7,1	84-72,4	11	8
2.00 x 60°S	10	7,3	86,4-74,5	11	9
	12	8	94,6-81,6	11,5	12
2.25 x 60°S	10	8,5	100,6-86,7	12,5	14
	12	9,5	112,4-96,9	13	18
2.50 x 60°S	10	9,5	112,4-96,9	13	18
	11	10	118,3-102	14,5	20



**TABEL PRIVIND DEBITELE SI POZITIONAREA CLAPETEI DE AER - MODEL GX3...**

Tablul ofera informatii pentru reglarea maxima a admisiei aerului pentru camera de ardere cu presiunea de 0,01 mbar. Reglarea definitiva trebuie facuta in timpul functionarii cu ajutorul unui analizor de gaze.



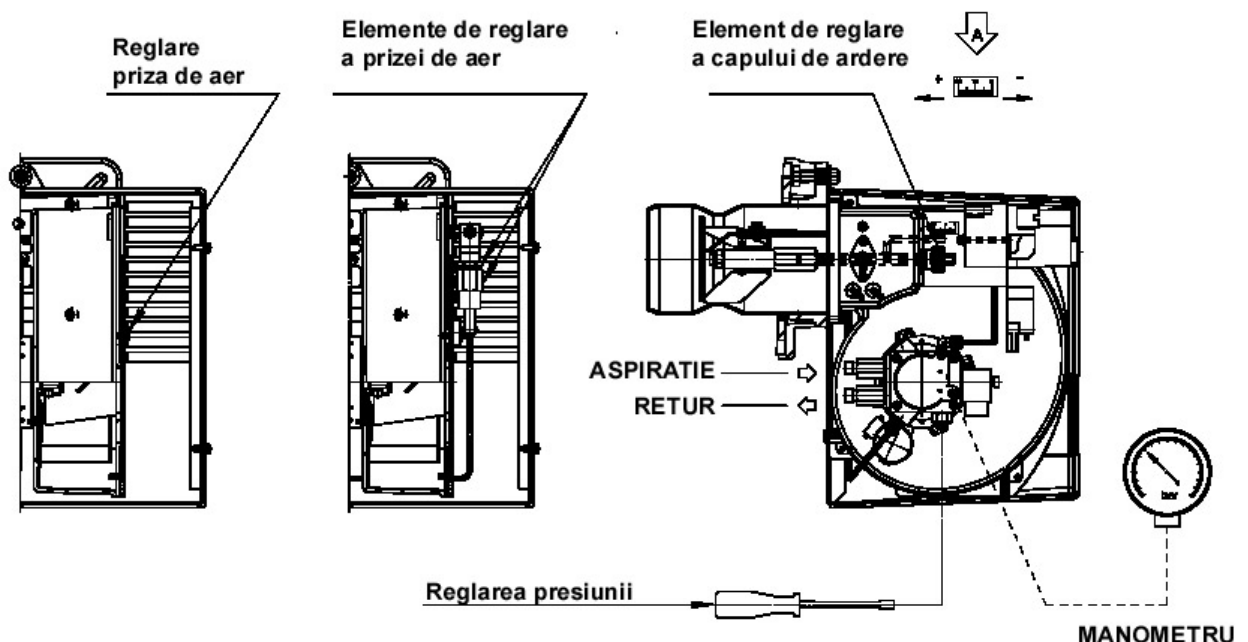



 DIUZA G.P.H. x grade	 PRESIUNE [bar]	 DEBIT [kg/h]	 PUTERE TERMICA [kW-Mcal/h]	 CLAPETA AER [Nr. gradatii]	 CAP ARDERE [Nr. gradatii]
1.75 x 60°S	12	7	83-72	15°	6
2.00 x 60°S	12	8	95-82	15°	8
2.25 x 60°S	12	9	107-92	17.5°	10
2.50 x 60°S	12	10	119-102	20°	12
2.75 x 60°S	12	11	131-112	22.5°	14
3.00 x 60°S	12	12	142-122	25°	15
3.50 x 60°S	10	13	154-133	27.5°	17
3.50 x 60°S	12	14	166-143	30°	18
3.50 x 60°S	14	15	178-153	30°	20



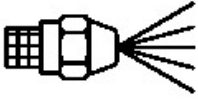

**TABEL PRIVIND DEBITELE SI POZITIONAREA CLAPETEI DE AER - MODEL GX4...**

Taboul ofera informatii pentru reglarea maxima a admisiei aerului pentru camera de ardere cu presiunea de 0,01 mbar. Reglarea definitiva trebuie facuta in timpul functionarii cu ajutorul unui analizor de gaze.

 DIUZA G.P.H. x grade	 PRESIUNE [bar]	 DEBIT [kg/h]	 PUTERE TERMICA [kW-Mcal/h]	 CLAPETA AER [Nr. gradatii]	 CAP ARDERE [Nr. gradatii]
2.50 x 60°S	12	10	118-102	15°	3
2.75 x 60°S	11	11	130-112	17.5°	4
3.00 x 60°S	12	12	142-122	20°	6
3.50 x 60°S	10	13	154-133	22.5°	7
	12	14	166-143	22.5°	9
4.00 x 60°S	10	15	177-153	25°	10
	12	16	189-163	27.5°	12
4.50 x 60°S	11	17	201-173	27.5°	14
	12	18	213-184	30°	16
5.00 x 60°S	10	19	225-194	35°	19
	11	20	236-204	45°	20

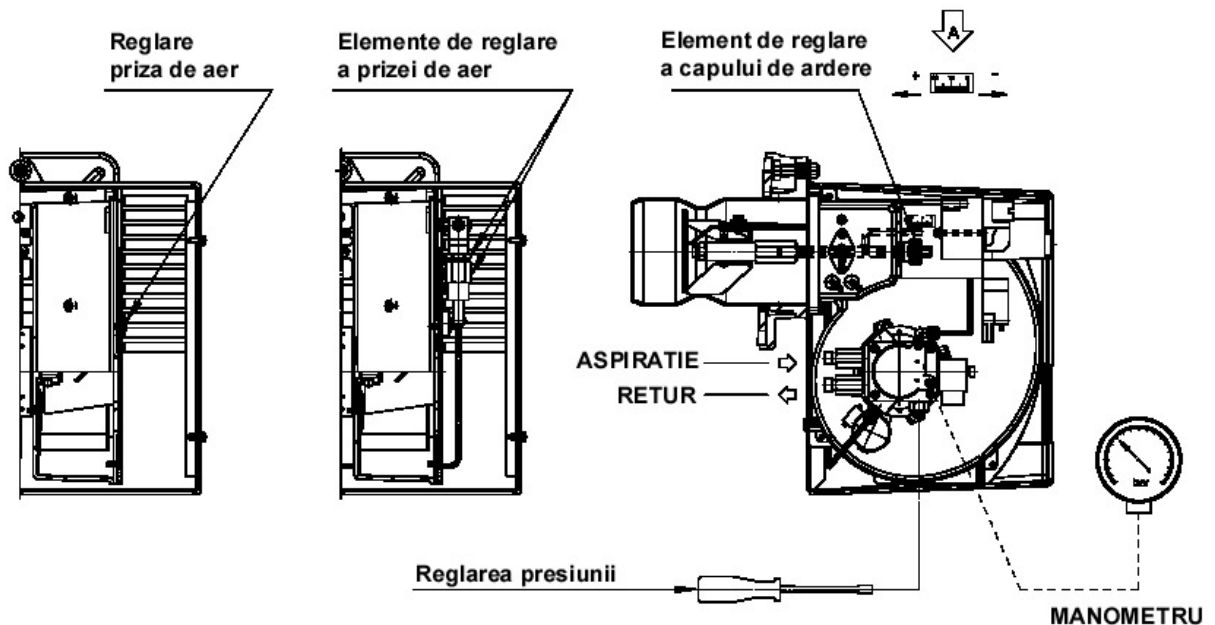

SCHEMA ELECTRICA G0...;G1...;G2...

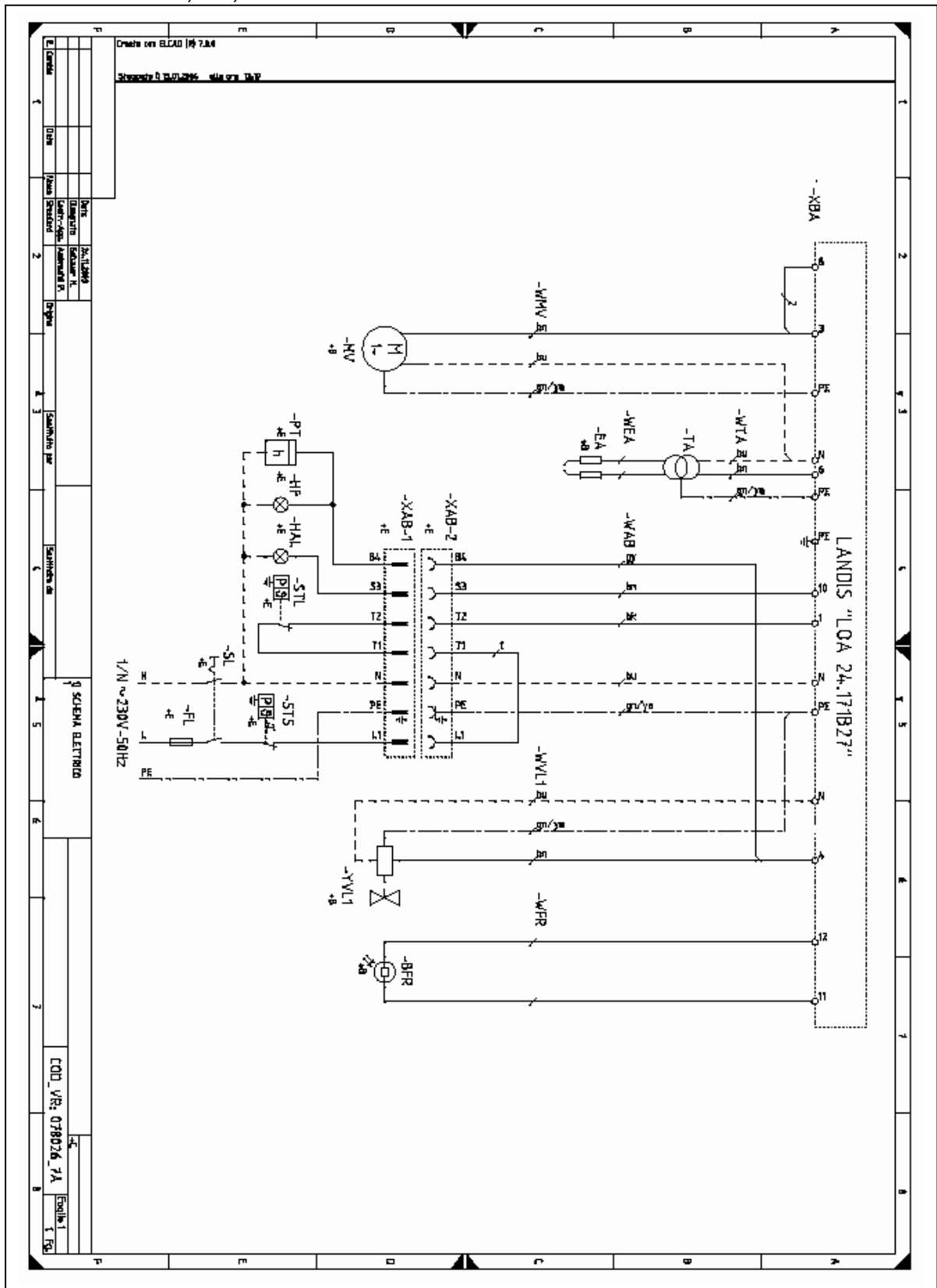

**ARZATOARE PE MOTORINA CU O SINGURA TREAPTA****MODEL:**  
G0...-G1...-G2...  
GX3...-GX4...**LEGENDA**

Nr.	SIMBOL IDENTIFICARE	LOC.	DESCRIERE
1	-BFR	+B	Fotorezistenta
2	-EA	+B	Electrod de aprindere
3	-MV	+B	Motor ventilator
4	-YVL1	+B	Valva motorina treapta 1
5	-TA	+C	Transformator de aprindere
6	-FL	+E	Fuzibil de linie
7	-HAL	+E	Lampa de bloc (de avarie)
8	-HF	+E	Lampa de functionare
9	-PT	+E	Contor orar
10	-SL	+E	Intreuptor de linie
11	-STL	+E	Termostat de lucru
12	-STS	+E	Termostat de siguranta
13	-XAB-1	+E	Soclu alimentare arzator
14	-XAB-2	+E	Priza alimentare arzator
15	-XBA	+C	Soclu automatului

**AVERTIZARI**

RESPECTATI NORMELE FUNDAMENTALE DE SIGURANTA,  
ASIGURATI-VA CA IMPAMANTAREA ESTE REALIZATA CORESPUNZATOR,  
PREVEDETI UN INTRERUPATOR DIFERENTIAL MAGNETOTERMIC PENTRU CONECTAREA LA RETEA.

REALIZATI CONEXIUNILE ELECTRICE ALE CABLULUI DE ALIMENTARE LA BORNELE DIN CUTIA TERMINALA A ARZATORULUI PENTRU A VA ASIGURA CA CONDUCTORUL DE IMPAMANTARE ESTE MAI LUNG DECAT CELE DE FAZA SI DE NUL

VERIFICATI ROTIREA CORECTA A MOTORULUI

CULORI: bk: negru bn: maro gy: gri  
bu: albastru gn/ye: galben/verde

TIP CONDUCTOR:

N

PE  $\perp$

CONEXIUNI OPTIONALE

CARE TREBUIE REALIZATE NUMAI DE CATRE UN INSTALATOR SPECIALIZAT.

LOCATII: +B: ARZATOR +C: CABLAJ +E: EXTERN +S: REZERVOR

**NU SCHIMBATI FAZA CU NULUL!**

DACA LAMPA DE INDICARE AVARIE NU ESTE INSTALATA, SE VA IZOLA CONDUCTORUL MARO CORESPONDENT AL CABLULUI -WAB.

**CALOR SRL**

Str. Progresul. nr. 30-40, sect. 5, Bucuresti  
Tel/fax: 021/4114444; 4113614 [www.calor.ro](http://www.calor.ro) – [calor@calor.ro](mailto:calor@calor.ro)



**ARZATOARE PE MOTORINA CU O SINGURA TREAPTA****MODEL:**  
**G0...-G1...-G2...**  
**GX3...-GX4...****LEGENDA**

Nr.	SIMBOL IDENTIFICARE	LOC.	DESCRIERE
1	-BFR	+B	Fotorezistenta
2	-EA	+B	Electrod de aprindere
3	-FL	+E	Fuzibil de linie
4	-HAL	+E	Lampa de bloc (de avarie)
5	-HF	+E	Lampa de functionare
6	-MV	+B	Motor ventilator
7	-PT	+E	Contor orar
8	-SL	+E	Intreruptor de linie
9	-STL	+E	Termostat de lucru
10	-STS	+E	Termostat de siguranta
11	-TA	+C	Transformator de aprindere
12	-XAB-1	+C	Soclu alimentare arzator
13	-XAB-2	+C	Priza alimentare arzator
14	-XBA	+C	Soclu automatului
15	-YVL1	+B	Valva motorina treapta 1

**AVERTIZARI**

RESPECTATI NORMELE FUNDAMENTALE DE SIGURANTA,  
ASIGURATI-VA CA IMPAMANTAREA ESTE REALIZATA CORESPUNZATOR,  
PREVEDETI UN INTRERUPATOR DIFERENTIAL MAGNETOTERMIC PENTRU CONECTAREA LA RETEA.

REALIZATI CONEXIUNILE ELECTRICE ALE CABLULUI DE ALIMENTARE LA BORNELE DIN CUTIA TERMINALA A ARZATORULUI PENTRU A VA ASIGURA CA CONDUCTORUL DE IMPAMANTARE ESTE MAI LUNG DECAT CELE DE FAZA SI DE NUL

VERIFICATI ROTIREA CORECTA A MOTORULUI

CULORI: bk: negru bn: maro  
bu: albastru gn/ye: galben/verde

TIP CONDUCTOR: N -----  
PE  $\perp$  - - - - -  
CONEXIUNI OPTIONALE -----

CARE TREBUIE REALIZATE NUMAI DE CATRE UN INSTALATOR SPECIALIZAT.

LOCATII: +B: ARZATOR +C: CABLAJ +E: EXTERN +S: REZERVOR

**NU SCHIMBATI FAZA CU NULUL!**

**CALOR SRL**

Str. Progresul. nr. 30-40, sect. 5, Bucuresti  
Tel/fax: 021/4114444; 4113614 [www.calor.ro](http://www.calor.ro) – [calor@calor.ro](mailto:calor@calor.ro)